

Nitric Oxide Calibration Source™

2B Technologies, Inc.



OPERATION MANUAL

Model 408

© Copyright 2008-2015, 2B Technologies, Inc.
All rights reserved.

Table of Contents

Table of Contents	ii
<i>IDENTIFICATION RECORDS</i>	iii
<i>PRINTING HISTORY</i>	iv
<i>WARRANTY STATEMENT</i>	v
1. NITRIC OXIDE CALIBRATION™ SOURCE INTRODUCTION	1
2. OPERATION	6
3. MAINTENANCE/TROUBLESHOOTING	15

IDENTIFICATION RECORDS

Record the following information for future reference:

Unit serial number: _____

Warranty start date: _____
(date of receipt)

PRINTING HISTORY

New editions are complete revisions of the manual and incorporate all previous update pages and write-in instructions. This manual will be revised as necessary. Revisions can be in the form of new editions, update pages, or write-in instructions.

Revision A.....January 2007

Revision B.....June 2007

Revision C..... February 2008

Revision D..... March 2015

TRADEMARKS & PATENTS

2B Technologies™, 2B Tech™, 2B™ and NO Calibration Source™ are trademarks of 2B Technologies, Inc.

CONFIDENTIALITY

The information contained in this manual may be confidential and proprietary, and is the property of 2B Technologies, Inc. Information disclosed herein shall not be used to manufacture, construct, or otherwise reproduce the goods disclosed herein. The information disclosed herein shall not be disclosed to others or made public in any manner without the expressed written consent of 2B Technologies, Inc.

© Copyright 2008, 2B Technologies, Inc.
All rights reserved.

WARRANTY STATEMENT

2B Technologies, Inc. warrants its products against defects in materials and workmanship. 2B Technologies will, at its option, repair or replace products which prove to be defective. The warranty set forth is exclusive and no other warranty, whether written or oral, is expressed or implied. 2B Technologies specifically disclaims the implied warranties of merchantability and fitness for a particular purpose.

Warranty Periods

The warranty period is one (1) year from date of receipt by the purchaser, but in no event more than thirteen (13) months from original invoice date from 2B Technologies, Inc.

Warranty Service

Warranty Service is provided to customers through phone support, Monday - Friday, from 9:00 a.m. to 5:00 p.m., Mountain Time USA and via our web-based Technical Support system at www.twobtech.com/techsupport where a customer support ticket may be logged. In some cases the instrument may be repaired by the customer using parts supplied by 2B Tech. If a customer repair is not possible or effective, the product may be returned to 2B Technologies for repair or replacement. Prior to returning the product, a Returned Merchandise Authorization (RMA) number must be obtained from the 2B Technologies Service Department and an RMA form completed. The RMA form allows us to identify the owner of the instrument and provides a return shipping address. Please do not return any of the accessories (power pack, serial cable, connecting tubing, etc.) with the instrument.

Shipping

2B Technologies will pay freight charges for replacement or repaired products shipped to the customer. Customers shall pay freight charges for all products returned to 2B Technologies.

Conditions

The foregoing warranty shall not apply to defects resulting from improper or inadequate maintenance, adjustment, calibration or operation by the customer. Maintenance, adjustment, calibration or operation must be performed in accordance with instructions stated in the Nitric Oxide Calibration Source™ manual. Usage of maintenance materials purchased from suppliers other than 2B Technologies will void this warranty.

Limitation of Remedies and Liability

The remedies provided herein are the Customer's sole and exclusive remedies. In no event shall 2B Technologies be liable for direct, indirect, special, incidental or consequential damages (including loss of profits) whether based on contract, tort or any other legal theory. The Nitric Oxide Calibration Source™ manual is believed to be accurate at the time of publication and no responsibility is taken for any errors that may be present. In no event shall 2B Technologies be liable for incidental or consequential damages in connection with or arising from the use of the Nitric Oxide Calibration Source™ manual and its accompanying related materials. Warranty is valid only for the country designated on the 2B Technologies quote or invoice.

Safety Warning

The Nitric Oxide Calibration Source is designed specifically to produce nitric oxide (NO) dilute in ambient air. Nitric oxide is a toxic gas and should be handled with caution. The same kind of care should be taken in handling the output of the Nitric Oxide Calibration Source as for NO dispensed from a compressed gas cylinder. Under normal operating conditions, the instrument will produce nitric oxide in air at concentrations up to ~2 ppm; however, an instrument failure could result in small volumes of air containing NO at higher concentrations. The NIOSH exposure limit for nitric oxide is 25 ppm (8-hour time weighted average).

The output of the NO Calibration Source also contains approximately 3% nitrous oxide (N₂O). The nitrous oxide is supplied by a cartridge containing liquid N₂O having a vapor pressure inside the cartridge of 58.5 bar at 20 °C. These cartridges are the same or similar to ones sold as a consumer product for producing whipped cream. Nitrous oxide or “laughing gas” is also used as a general anesthetic at concentrations up to 50% and is thus well tolerated by humans. There are no known toxicological effects of N₂O other than asphyxiation at extremely highly concentrations due to exclusion of oxygen. N₂O is not itself combustible, but it strongly supports combustion of organic materials and reducing agents. Contact with liquid N₂O can cause frost bite due to cooling as the liquid rapidly evaporates.

N₂O Cartridge and Regulator Warnings:

- Do not exceed the minimum or maximum temperature listed on the N₂O cartridges.
- Store N₂O cartridges out of the reach of children.
- Do not use N₂O cartridges for any purposes not described in this manual.
- Never use excessive force to remove or install N₂O cartridges. Contact 2B Tech if you are having trouble installing or removing cartridges.
- Whenever there is a pressurized N₂O cartridge in the regulator assembly, keep the instrument level and do not invert the N₂O cartridge.
- Do not make any modifications or repairs to the pressure regulator assembly yourself.

- Never use the pressure regulator assembly if dropped or damaged (e.g., cracked or dented). If the pressure regulator is dropped or damaged, it should be returned to 2B Tech for a safety inspection.

The MSDS sheets for NO and N₂O are included as an appendix at the end of this manual.

ENGLISH



WARNING:

Any operation requiring access to the inside of the equipment, could result in injury. To avoid potentially dangerous shock, disconnect from power supply before opening the equipment.



WARNING:

This symbol,  on the instrument indicates that the user should refer to the manual for operating instructions.

WARNING:

If this instrument is used in a manner not specified by 2B Technologies, Inc. USA, the protection provided by the instrument may be impaired.

ESPAÑOL



ATENCIÓN:

Cualquier operación que requiera acceso al interior del equipo, puede causar una lesión. Para evitar peligros potenciales, desconectarlo de la alimentación a red antes de abrir el equipo.



ATENCIÓN:

Este símbolo,  en el instrumento indica que el usuario debería referirse al manual para instrucciones de funcionamiento.

ATENCIÓN:

Si este instrumento se usa de una forma no especificada por 2B Technologies, Inc., USA, puede desactivarse la protección suministrada por el instrumento.

FRANÇAIS



ATTENTION:

Chaque opération à l'intérieur de l'appareil, peut causer du préjudice. Afin d'éviter un choc qui pourrait être dangereux, déconnectez l'appareil du réseau avant de l'ouvrir.



ATTENTION:

Le symbole,  indique que l'utilisateur doit consulter le manuel d'instructions.

ATTENTION:

Si l'instrument n'est pas utilisé suivant les instructions de 2B Technologies, Inc., USA, les dispositions de sécurité de l'appareil ne sont plus valables.

DEUTSCH



WARNHINWEIS:

Vor dem Öffnen des Gerätes Netzstecker ziehen!



WARNHINWEIS:

Dieses,  auf dem Gerät weist darauf hin, daß der Anwender zuerst das entsprechende Kapitel in der Bedienungsanleitung lesen sollte.

WARNHINWEIS:

Wenn das Gerät nicht wie durch die Firma 2B Technologies, Inc., USA, vorgeschrieben und im Handbuch beschrieben betrieben wird, können die im Gerät eingebauten Schutzvorrichtungen beeinträchtigt werden.

ITALIANO



ATTENZIONE:

Qualsiasi intervento debba essere effettuato sullo strumento può essere potenzialmente pericoloso a causa della corrente elettrica. Il cavo di alimentazione deve essere staccato dallo strumento prima della sua apertura.



ATTENZIONE:

Il simbolo,  sullo strumento avverte l'utilizzatore di consultare il Manuale di Istruzioni alla sezione specifica.

ATTENZIONE:

Se questo strumento viene utilizzato in maniera non conforme alle specifiche di 2B Technologies, Inc. USA, le protezioni di cui esso è dotato potrebbero essere alterate.

DUTCH



OPGELET:

Iedere handeling binnenin het toestel kan beschadiging veroorzaken. Om iedere mogelijk gevaarlijke shock te vermijden moet de aansluiting met het net verbroken worden, vóór het openen van het toestel.



OPGELET:

Het symbool,  geeft aan dat de gebruiker de instructies in de handleiding moet raadplegen.

OPGELET:

Indien het toestel niet gebruikt wordt volgens de richtlijnen van 2B Technologies, Inc., USA gelden de veiligheidsvoorzieningen niet meer.

1. NITRIC OXIDE CALIBRATION™ SOURCE INTRODUCTION

The Nitric Oxide Calibration Source™ is a portable source of nitric oxide that allows one to calibrate any nitric oxide monitor. The instrument scrubs NO from ambient air and produces either zero air or air having a mixing ratio of NO in the range 10-1,000 parts-per-billion by volume (ppbv). The desired NO concentration is chosen from the easy-to-use menu using a rotary select switch. The instrument can be programmed to output up to 10 individual NO step concentrations over a chosen time interval. The total output volumetric flow rate is 3.5 L/min, and the NO mixing ratio is controlled so as to be independent of ambient temperature, pressure and humidity.

You can attach the NO Calibration Source™ output directly to the inlet of any nitric oxide monitor (providing that its sampling rate is less than 3.0 L/min); the excess flow must be vented through an external overflow tee. Besides portability, an important advantage of the Model NO Calibration Source is that it provides a known concentration of NO in ambient air containing the same level of humidity as the air sample to be measured.

The NO Calibration Source™ is factory calibrated against a NIST-traceable standard. However, the calibration parameters may be changed in the menu in case the user wants to recalibrate the NO Calibration Source™ against a separately maintained standard; i.e., the NO Calibration Source™ can be used as a transfer standard. The NO Calibration Source™ may be used, for example, for maintaining the calibration of a large number of NO monitors in the field relative to a highly stable laboratory instrument. In this case, a huge advantage of the NO Calibration Source™ is its portability.

Theory of Operation

The Nitric Oxide Calibration Source™ makes use of a low pressure mercury lamp to photolyze nitrous oxide (N₂O) and produce NO in a patent-pending process. The vacuum UV emission lines of mercury near 185 nm are absorbed by N₂O to produce electronically excited oxygen atoms, O (¹D₂). A large fraction of these highly energetic oxygen atoms react with N₂O to form NO:

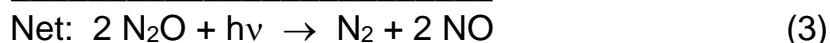
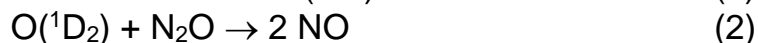
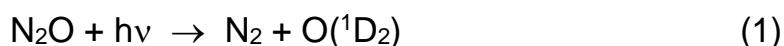

where $h\nu$ symbolizes a photon of light. Other reactions produce a small amount of molecular oxygen as well. The concentration of NO produced in a flowing stream of air depends on the intensity of the photolysis lamp, the concentration of N₂O (determined by pressure and temperature), and the residence time in the photolysis cell (determined by volumetric flow rate and cell volume). By holding these parameters constant, it is possible to produce a flow of air containing a constant concentration of NO, and the concentration of NO produced can be varied most conveniently by varying the lamp intensity. Figure 1 is a schematic diagram of the NO Calibration Source.TM

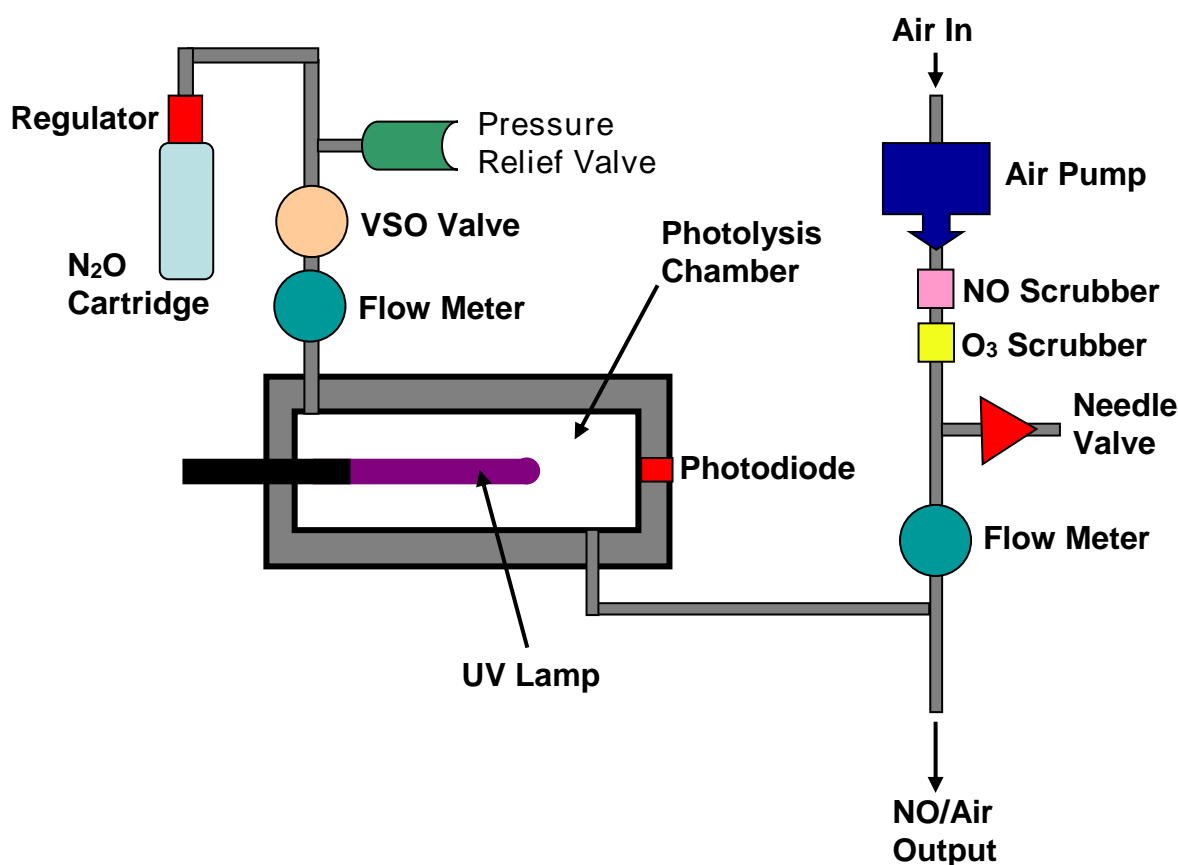

Figure 1. Schematic diagram of the NO Calibration SourceTM.

An air pump draws air in through NO and ozone scrubbers to remove any ambient NO. The air flow rate is controlled by use of restrictors (not shown) and a needle valve that vents part of the flow and is measured by a flow meter. A constant fraction of the flow bypasses the flow meter (not shown) so that the flow through the meter is in the range 0-1 L/min. The needle valve is adjusted

to produce a total output volumetric flow rate of ~3.5 L/min. Nitrous oxide is supplied by a cartridge containing liquid N₂O with a headspace pressure of ~50 atmospheres. The internal pressure is dropped by a combined cracker/regulator and additional flow restrictor, which also is used to provide coarse adjustment of the flow rate of N₂O to be in the range 60 ± 10 cc/min. A pressure relief valve inside the instrument housing prevents over pressurization by opening to the atmosphere if the pressure exceeds 25 psig. A Voltage Sensitive Orifice (VSO) valve is used to provide fine control of the N₂O flow rate to ~60 ± 1 cc/min. Within the photolysis chamber, a very small fraction of the N₂O is converted to NO and N₂ by absorption of light at wavelengths near 185 nm. Measurements of the output of the photolysis chamber show that no insignificant concentration of NO₂ is produced. The lamp intensity at 254 nm is monitored by a photodiode and controlled by the microprocessor. The photodiode voltage is calibrated against the output NO concentration. Pressure within the gas stream is measured but not controlled. Instead, the lamp intensity is varied to compensate for changes in pressure and flow rate using a proprietary algorithm. Air containing nitric oxide at a selected concentration in the range 0-1,000 parts-per-billion by volume exits the instrument.

NITRIC OXIDE CALIBRATION SOURCE™ SPECIFICATIONS

Indoor Use Only

Ordinary Protection (Not protected against harmful ingress of moisture)

Electrical Power Input Rating of

NO Calibration Source™ 12 V dc, 2.5 A

External Power Supply:

Mains Supply Input 100-240 V~, 50-60 Hz

Class I Equipment (Grounding Required for Safety)

Installation (Overvoltage) Category II for Transient Overvoltages

Pollution Degree 2

Output..... 12 V dc, 2.5 A

Mains supply voltage fluctuations are not to exceed $\pm 10\%$ of the nominal supply voltage.

Relative Humidity Range 0-80%, Non Condensing

Operating Temperature Range..... 10-40 °C

Transportation and Storage Temperature Ranges -20-60 °C

Altitude Range 0-2000 m

Dimensions..... 3.7 x 8.5 x 9.5 in (9.4 x 21.6 x 24.1 cm)

Weight 5.2 lbs (2.4 kg)

NO Output 0 ppb and 20-1,000 ppb

Output Flow Rate..... 3.5 L/min volumetric

Precision..... higher of 3.0 ppbv or 3% of concentration

Accuracy..... higher of 3.0 ppbv or 3% of concentration

Rise Time (95%)..... < 30s to reach 95% of selected concentration

Data Outputs RS232, LCD Display

MEANING OF SYMBOLS ON BACK PANEL OF INSTRUMENT

N_2O
 Inlet connector for N_2O

NO
 Outlet connector for NO in Air

 Certified Compliant with CE regulations of the European Union.

WARNINGS

USE ONLY SUPPLIED A/CDC ADAPTER

WARNING: This device produces toxic gas. The toxic gas produced is nitric oxide (NO) dilute in air. The purpose of the instrument is to produce known concentrations of NO /Air in the range 10-1000 ppb. Please see the Safety Warning on page vi and consult the MSDS for NO included as an appendix to this manual.

LIST OF ACCESSORIES

- N_2O Cartridges (8 g)
- Serial port cable
- Tubing Connector to NO Measurement Device
- Serial-to-USB converter

2. OPERATION

Please read all the following information before attempting to install the Nitric Oxide Calibration Source™. For assistance, please call 2B Technologies at (303)273-0559 or email us at techsupport@twobtech.com.

NOTE:

Save the shipping carton and packing materials that came with the NO Calibration Source™. If the instrument must be returned to the factory, pack it in the original carton. Any repairs as a result of damage incurred during shipping will be charged.

Shipping Box Contents

Open the shipping box and verify that it contains all of the items on the shipping list. If anything is missing or obviously damaged, contact 2B Technologies immediately.

Attachment of the N₂O Cartridge

Nitrous oxide is supplied to the instrument by means of N₂O cartridges. Each cartridge contains ~16 g of liquid N₂O and will supply a gas flow of N₂O of 50 mL/min for ~2.5 hours. Thus, several calibrations can be carried out using a single cartridge. The pressure inside the cartridge remains nearly constant as N₂O evaporates and flows out of the cartridge. The evaporation of N₂O causes the N₂O cartridge to cool, which, in turn, slightly reduces the internal pressure of ~50 atmospheres.

Warning: If an N₂O cartridge is punctured outside the cracker/regulator, liquid N₂O can escape, and if it evaporates on skin it will cause frost bite. The cartridge will also act as a “rocket” if the seal is punctured outside the cracker/regulator. However, the N₂O cartridges are commonly used consumer products available in grocery stores and are safe to handle if the following procedure is followed.

To attach the N₂O cartridge follow these steps:

- 1) Make sure N₂O flow is off by closing regulator knob (turn all the way clockwise)
- 2) Remove bottom black cartridge holder, place a 16g N₂O cartridge into black holder and re-insert by screwing into regulator.

CAUTION: Be sure pressure relief hole, located just above black cartridge holder on the regulator is not pointed at you when installing a new N₂O cartridge.

- 3) When prompted by 408 LCD to set the N₂O flow open regulator by turning black knob counter-clockwise until the desired flow of 60cc/min is achieved. Generally a ¼- ½ turn of the knob will work.

Attaching the NO Calibration Source™ to a NO Monitor

For calibration of a NO Monitor, outlet tubing may be attached to the ¼-inch nylon Swagelok fitting on the back of the instrument. The inlet tubing should be made of PTFE (Teflon®), PFA or some other inert material that does not destroy NO and that does not desorb plasticizers and other organics that can contaminate the flow path. The length of tubing should be kept as short as possible (not more than a few feet) to minimize NO loss and an unrestrictive over flow T is needed at the inlet of the NO monitor to be calibrated. Tygon®, polypropylene (which may look like Teflon) and metal tubing should not be used. Teflon-lined Tygon tubing, which is supplied with the instrument provides the flexibility of Tygon and the inertness of Teflon.

Operation of the Nitric Oxide Calibration Source™

To operate the Nitric Oxide Calibration Source™, connect it to an external power source and turn the instrument on by flipping the front panel switch. The instrument requires a 12 V DC source which is supplied by the 110-220 V AC power adapter (2.5 amp) provided. Do not use any other power adapter.

Once turned on, the instrument will briefly display the version number of the software installed on the microprocessor. The instrument will then display

Warming up ...
delT = -xx.x

where **delT** is the deviation of the temperature of the photolysis chamber from the set point of 310 K (37 °C). As the chamber warms up, the temperature deviation will be continuously displayed. During the warm up period, the photolysis lamp is turned off.

Once **delT** is within 1 °C of the set point, the display will briefly read

Temperature Set

followed by a brief display of:

Set N2O Flow

This will be followed by a prompt to open the regulator of the N₂O cartridge and set the flow rate:

Target=60 +/-10
N2O Flow = xx.x

where xx.x is the measured N₂O flow rate. At this point turn the black knob on the N₂O regulator until the measured flow is in the range 40-60 mL/min. Once the flow is in range, press the select switch. When menu appears, release the select switch. (Note: You may enter the menu without waiting for the warm up to be complete and without setting the N₂O flow rate; however the NO concentration selected will not be accurately output unless the NO flow is in the appropriate range and the set point temperature is reached.) The main menu will be displayed as:

Menu
200 1000 Flw Adv

Rotating the select switch will move the blinking cursor to highlight the first character of each of the four submenus, **200**, **1000**, **Flw** and **Adv**. One can enter any one of these submenus by rotating the select switch to move the blinking cursor over the first letter of the submenu and then momentarily pressing (“clicking”) the select switch. Selecting either **200** or **1000** will have the 408 output NO concentrations of 200ppbv or 1000ppbv respectively.

Flw (Flow Submenu)

Choosing the Flw submenu allows one to continuously view the air flow rate (Air) and N₂O Flow rate (N₂O). The flow rates are displayed on the LCD in VOLUMETRIC FLOW (cc/min) and displayed over the serial line in MASS FLOW (cc/min), for example, as follows:

Air = 3012 cc/min
N₂O = 65.7 cc/min

This menu may be used to adjust the air flow rate using the recessed needle valve in the back of the instrument as described below, and the N₂O flow rate using the N₂O regulator valve.

Note: In order to obtain accurate results, the air flow rate may need to be adjusted to 3.5 L/min when first used. This is because the air flow was set at an altitude of 1.6 km and the air pump may produce a different flow rate at other altitudes. The instrument compensates for variations in flow rate, but for best results the flow should be as close to 3.5 L/min as possible. To set the air flow rate, enter the **Cfg/Flw** submenu and use a flathead screwdriver to adjust the air flow needle valve on the back of the instrument until the flow reads close to 3.5 L/min. Rotating the valve clockwise increases the air flow rate, and counter clockwise decreases the flow rate.

Adv (Advanced Submenu)

Selecting **Adv** will access the advanced menu and the LCD will display:

Cfg NO Zer

Configuration Menu (Cfg)

Selecting the **Cfg** menu will produce the following display:

Cfg Menu
Err Prg Run ←

The purpose of the return symbol (←) is to return to the previous menu; i.e., depressing the select switch when ← is highlighted allows one to move one level up in the menu.

Err is a submenu for displaying error code definitions across the LCD. The user can scroll through the error code definitions by rotating the select knob. The list of error codes and definitions can be found at the end of this manual below.

Prg is a submenu for defining a programmed series of step NO concentrations,

Choosing **Prg** results in the following submenu:

Prg Menu
Num Steps= x ←

Upon placing the cursor under the currently set value x and clicking, a blinking cursor will appear. You may now rotate the select switch to obtain the number of steps, up to 10, you wish to have in your program. Clicking again will turn off the blinking cursor and you may return the cursor to ← to begin defining the program. After choosing the number of steps, the following submenu will appear:

Prg Menu
Time/Step= x ←

You may now move the cursor to the currently set time/step value x, click to obtain a blinking cursor and rotate the select switch to choose a step time in the range 1 to 60 minutes. (NOTE: the 408 will take a few minutes to get up to concentrations and it is recommended to run step functions for at least 8 minutes for best results) To select the value, click to remove the blinking cursor, then use ← to begin defining the target concentrations of each of the steps. The following submenu will now appear:

Select NO Step
Step[1]= xxxx ←

Where xxxx is the target NO concentration in ppbv that is currently being used for the first step of the program. You may now change the NO concentration for the first concentration step in the same way that the Time/step was changed. Executing ← will bring up the following submenu and allow you to set the target concentration for the next step:

Select NO Step
Step[2]= xxxx ←

This process is repeated until the target concentrations are set for all of the steps in your program.

This program resides in memory until the next time you choose to change it.

Run

Choosing **Run** executes the program of concentration steps you have stored in memory (under **Adv/Prg**). The target concentrations are displayed as the instrument steps through the program. For example, the first display might read

Step[1]=100 ppb
delT=0.2 ■■■■■

if you have chosen 100 ppb as the target concentration for your first step and the photolysis chamber is higher than the target value by 0.2 °C. The five solid bars indicate that the cell temperature, N₂O flow rate, total flow rate and lamp intensity are within range for accurate output of the selected NO concentration. If any critical parameter or combination of parameters is out of range, an error code will appear in place of the bars.

NO (Nitric Oxide Menu)

By selecting **NO** from the **Adv** menu the user may choose to output a constant NO concentration. Upon selecting **NO**, the following submenu will appear:

Select Amount
NO= xxx ←

You may change the desired target NO concentration (20-1000ppbv) by selecting the individual digits (**x**) and rotating the select switch to choose a values for those digits, as described above for setting the calibration parameters.. To start producing that concentration of NO, click on ←. The instrument will now output the selected concentration of NO until you enter the menu again and change the target concentration. As an example, the display may read as follows

Target= 150 ppb
delT=-0.1 ■■■

if you have chosen 150 ppb as the target concentration and the instrument needs a few more seconds to reach that concentration (five bars).

The selected target NO concentration will remain in memory until the next time you change it. Bear in mind that the instrument will output 20-1,000 ppbv of NO reliably. It is not recommended using the 408 for concentrations less than 20ppb (other than zero) or concentrations greater than 1000ppbv.

Zer (Zero menu)

Selecting **Zer** from the **Adv** menu allows the user to produce zero air from the 408. This submenu provides a rapid way to produce air containing 0 ppb of NO. In this mode, the photolysis lamp is turned off. When running zero air the 408 LCD will display

Target= 0 ppb
delT=-0.1 ■■■

Reentering the Menu

The menu may be reentered at any time by holding in the select switch until the menu appears.

Viewing of Flow Rates Outside of the Menu

It is easy to view the instantaneous air and N₂O flow rates while outputting NO. Simply rotate the select switch one click clockwise to view the N₂O flow rate and one click to the left to view the air flow rate. The flow rates are also displayed on the serial output header.

Collecting Diagnostic Data over the Serial Port in Real Time

To transmit diagnostic data to a computer over the serial port in real time, connect the NO Calibration Source™ to the serial port of the computer using the 9-pin cable provided. If your computer does not have a serial port, you can use a serial-to-USB adapter, also provided with the instrument. Activate your data acquisition software; e.g., Hyperterminal (available on most Windows®-based computers) or Tera Term Pro (provided on the cd supplied with the instrument and downloadable from the 2B Tech website: www.twobtech.com). The latter software is preferred since Hyperterminal has a 500-line buffer limit, but the user may set the maximum buffer size for Tera Term Pro to 10,000 lines. Both programs allow you to log data to a computer file with no limit on the number of data lines. Using these terminal emulation programs, data may be saved to a text file and then opened in Microsoft Excel (or other spreadsheet program) where it may be converted to formatted data in columns by defining delimiters (such as commas and carriage returns) for data manipulation and graphing.

For data transfer the correct settings are:

Baud rate: 19,200

Data bits: 8

Parity: None

Stop bits: 1

Flow control: None or hardware

Serial data lines are output approximately once every second as follows:

Lamp Intensity (arbitrary units), Temperature (K), Pressure (Torr), Air Volumetric Flow Rate (mL/min), N₂O Volumetric Flow Rate (mL/min), Lamp Duty Cycle (%), Heater Duty Cycle (%), Target/Measured Lamp Intensity Ratio, Error Code

Collecting serial data for a few minutes can be extremely useful in diagnosing a problem with the Nitric Oxide Calibration Source™. If you have a problem, please collect a data file and email it to techsupport@twobtech.com along with a description of the problem.

Cal Menu

To access the calibration menu, where the instrument calibration factors are stored, hold down the select knob while powering on the instrument. The LCD will display,

Cal Menu
Fm1 Fm2 NO ←

Fm1: This is the flow meter cal factor for the N₂O flow. This is calibrated at 2B Technologies and it is strongly recommended to NOT change this cal factor.

Fm2: This is the cal factor for the output air flow of the 408 NO Calibration Source™. If the user has access to a reliable flow meter and finds a difference in actual flow v. flow readout this can be adjusted as needed. To determine the flow cal factor, set Fm2 =1.00 then use: (Actual vol. flow/readout vol. flow)=Fm2 cal factor and adjust this cal factor as needed.

NO (NO cal factors):

Selecting this option takes the user to the 408 NO cal factors and the LCD will display,

NO Cal Menu

Cal_l Cal_h ←

The 408 NO Calibration Source™ makes use of 2 sets of calibration factors both with Z (offset) and S (span) for different selected NO concentrations. Cal_l menu contains the low concentrations cal factors and uses these factors when selecting concentrations of 20-250ppbv. Cal_h is a different set of cal factors used when selecting concentrations 251-1000ppbv. Every 408 NO Calibration Source™ is shipped with a NIST-traceable calibration. The calibration factors, Both Cal_l and Cal_h calibration factors **Z** and **S**, are set in the instrument and recorded in the instrument's calibration document and birth certificate. However, you may choose to change the calibration factors so that the instrument output agrees with your own nitric oxide standard. You can always return the instrument to its factory calibration if desired. To change the calibration factor, place the cursor over the digit (**x**) you wish to change and hold in the select switch until the cursor blinks. You may now change the value of the digit by rotating the select switch. Once the desired value of a digit is selected, momentarily press the select switch such that the cursor no longer blinks. You may now rotate the select switch to choose another digit to change. The **Z** parameter is a "zero" or "offset", and the **S** parameter is a "gain" ("slope" or "sensitivity") factor. Increasing the **Z** parameter increases the concentration of NO produced in an additive way. For example, changing **Z** from 1.3 to 2.4 will cause the NO output to increase by 1.1 ppb. Increasing the **S** parameter increases the NO output concentration linearly; i.e., for S=1.10, the NO concentration produced will be 10% higher than for S=1.00, and for S=0.95 it will be 5% lower. Once the desired value of a digit is selected, momentarily press the select switch such that the cursor no longer blinks. You may now exit the **Cal** submenu by selecting and clicking on ←.

Error Codes

Error codes are displayed if any of the four key parameters (temperature, air flow rate, N₂O flow rate and lamp intensity) are out of range as follows:

Code	Error
1	N ₂ O flow out of range (40 – 80 mL/min)
2	Air flow rate out of range (3.3 – 3.8 L/min)
3	1 and 2
4	Temperature out of range (312 – 316 K)
5	1 and 4
6	2 and 4
7	1, 2 and 4
8	Ratio of lamp intensity to target intensity out of range (0.96 to 1.04)
9	1 and 8
10	2 and 8
11	1, 2 and 8
12	4 and 8
13	1, 4 and 8
14	2, 4 and 8
15	1, 2, 4 and 8

3. MAINTENANCE/TROUBLESHOOTING

The NO Calibration Source™ is designed to be nearly maintenance-free. The only component that requires routine maintenance is the NO scrubber, which should be changed at least once every six months of operation. Other user serviceable components include the lamp and air pump, both of which are easily replaced should they fail.

Cleaning: The exterior may be cleaned with a damp cloth after disconnecting the power adapter. Be sure that the instrument is dry before applying power. If the flow path becomes contaminated because of exposure to high levels of dust, smoke or chemical vapors, the instrument should be returned to 2B Technologies for cleaning of the internal flow path.

If the instrument fails to operate correctly, common problems can be identified and corrected using Table I. If the problem cannot be corrected, the instrument may be shipped to 2B Technologies for service. Please phone or email in advance to obtain a return authorization number and for shipping instructions.

The figures following Table I provide a “guided tour” of the instrument so that critical components and connectors may be easily identified.

Table I. *Troubleshooting the NO Calibration Source™ for performance problems.*

Problem/symptom	Likely cause	Corrective action
<i>Instrument does not turn on.</i>	Power not connected properly or circuit breaker open. Power cable not connected to circuit board.	Check external power connection for reverse polarity or a short and wait a few minutes for the thermal circuit breaker to reset. Remove top cover and disconnect and reconnect power cable to circuit board.
<i>Instrument turns on then powers off.</i>	Burned out air pump.	Remove top cover and unplug air pump. Turn instrument on; if it remains running, then the air pump motor is burned out and shorting. Replace air pump.
<i>Display is blank or nonsense.</i>	Bad connection of display to circuit board.	Remove top cover and reconnect display to circuit board. Check solder connections to display.
<i>Target temperature is</i>	Absent or loose	Remove top cover and

<i>never reached.</i>	connection of temperature probe cable to circuit board. Heater is burned out	reattach connector to circuit board. Replace cartridge heater.
<i>Instrument does not output NO.</i>	Photolysis lamp is burned out. Cable not properly connected between lamp and circuit board.	Replace lamp and recalibrate instrument. Remove top cover and reconnect lamp cable to circuit board.
<i>Select switch does not work.</i>	Cable not properly connected between select switch and circuit board.	Remove top cover and reconnect select switch cable to circuit board.
<i>Serial port does not work.</i>	Cable not properly connected between serial port 9-pin connector and circuit board. Wrong serial cable used. Wrong baud rate selected.	Remove top cover and reconnect serial port cable to circuit board. A “straight through” serial cable is provided. Some data collection devices require a “cross over” cable in which pins 1 and 3 are exchanged between the two ends of the cable. Use a “cross over cable or additional connector that switches pins 1 and 3. Make sure that the baud rate on your data collection program (e.g., Tera Term Pro or Hyperterminal) is set to 4800.

	Wrong com port assigned.	Make sure that the com port assigned by your computer matches the com port setting in your data collectin program (e.g., Tera Term Pro or Hyperterminal).
--	--------------------------	---

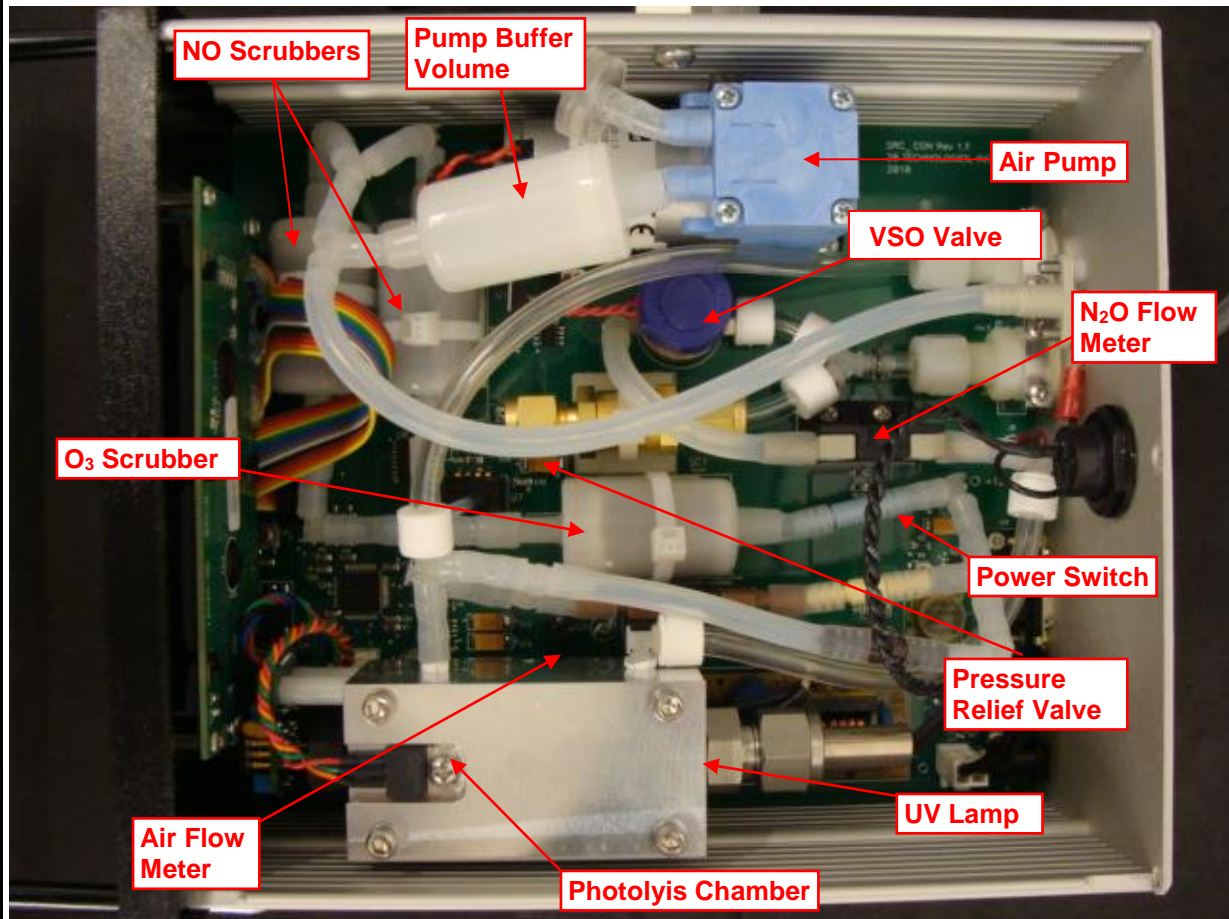

Figure 2. Top view of NO Calibration Source™ with top cover removed.

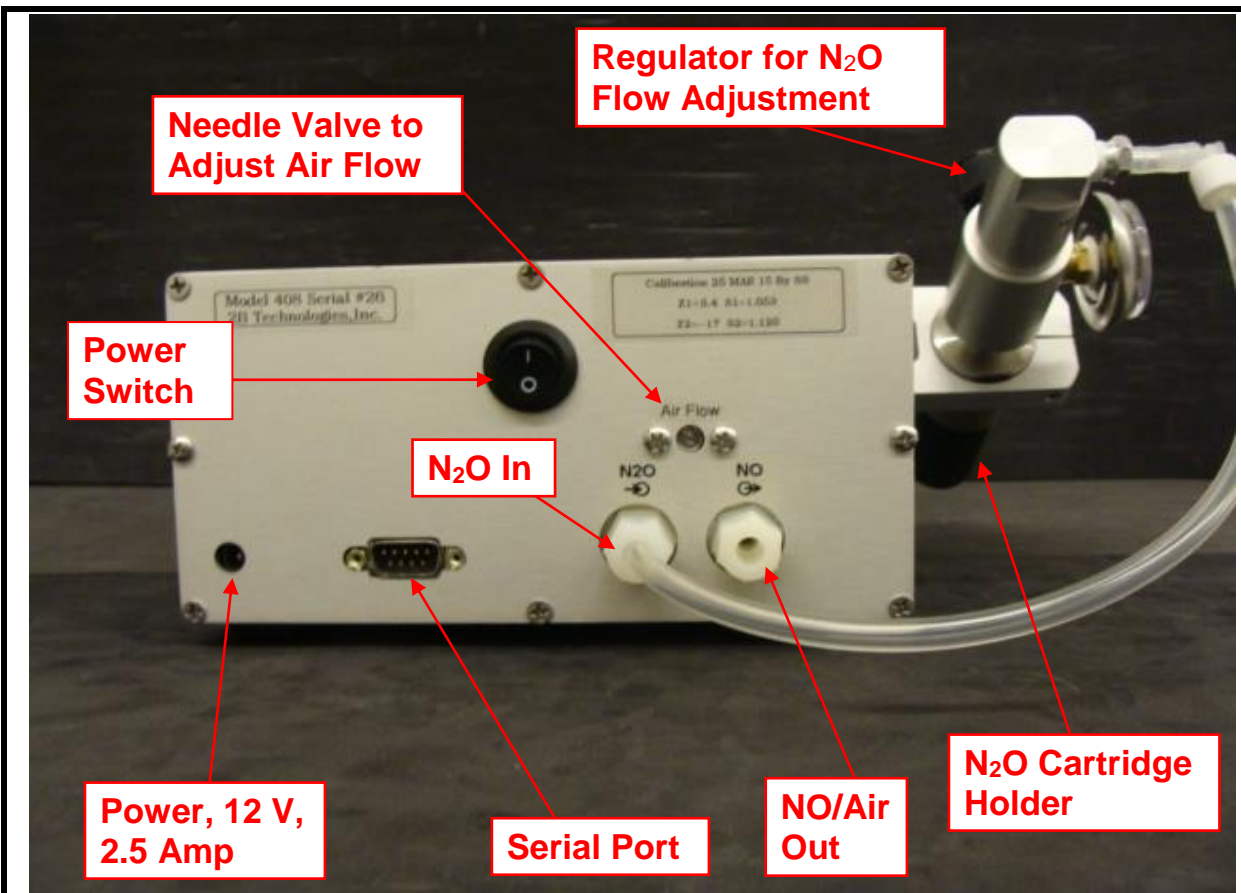

Figure 2. Rear view of NO Calibration Source™.