

NO₂ Converter

2B *Technologies, Inc.*

OPERATION MANUAL

Model 401

© Copyright 2013, 2B Technologies, Inc.
All rights reserved.

TABLE OF CONTENTS

<i>IDENTIFICATION RECORDS</i>	iii
<i>PRINTING HISTORY</i>	iv
<i>WARRANTY STATEMENT</i>	v
<i>WARNINGS</i>	vii
<i>NO₂ CONVERTER INTRODUCTION</i>	1
<i>SPECIFICATIONS</i>	2
<i>OPERATION</i>	3
<i>ELECTRICAL WIRING DIAGRAM</i>	7
<i>TROUBLE SHOOTING</i>	8

IDENTIFICATION RECORDS

Record the following information for future reference:

Unit serial number: _____

Warranty start date: _____
(date of receipt)

PRINTING HISTORY

New editions are complete revisions of the manual and incorporate all previous update pages and write-in instructions. This manual will be revised as necessary. Revisions can be in the form of new editions, update pages, or write-in instructions.

Revision A.....	January 2007
Revision B.....	January 2010
Revision C	January 2012
Revision D	March 2013
Revision E	April 2014

TRADEMARKS & PATENTS

2B Technologies™, 2B Tech™, 2B™, NO Monitor™, Nitric Oxide Monitor™ and NO₂ Converter™ are trademarks of 2B Technologies, Inc.

CONFIDENTIALITY

The information contained in this manual may be confidential and proprietary, and is the property of 2B Technologies, Inc. Information disclosed herein shall not be used to manufacture, construct, or otherwise reproduce the goods disclosed herein. The information disclosed herein shall not be disclosed to others or made public in any manner without the expressed written consent of 2B Technologies, Inc.

© Copyright 2013, 2B Technologies, Inc.
All rights reserved.

WARRANTY STATEMENT

2B Technologies, Inc. warrants its products against defects in materials and workmanship. 2B Technologies will, at its option, repair or replace products which prove to be defective. The warranty set forth is exclusive and no other warranty, whether written or oral, is expressed or implied. 2B Technologies specifically disclaims the implied warranties of merchantability and fitness for a particular purpose.

Warranty Periods

The warranty period is one (1) year from date of receipt by the purchaser, but in no event more than thirteen (13) months from original invoice date from 2B Technologies, Inc.

Warranty Service

Warranty Service is provided to customers through phone support, Monday - Friday, from 9:00 a.m. to 5:00 p.m., Mountain Time USA. Phone support is for trouble-shooting and determination of parts to be shipped from 2B Technologies to the customer in order to return the product to operation within stated specifications. If phone support is not efficient and effective, the product may be returned to 2B Technologies for repair or replacement. Prior to returning the product, a Repair Authorization Number (RA) must be obtained from the 2B Technologies Service Department.

Shipping

2B Technologies will pay freight charges for replacement or repaired products shipped to the customer site. Customers shall pay freight charges for all products returning to 2B Technologies.

Conditions

The foregoing warranty shall not apply to defects resulting from improper or inadequate maintenance, adjustment, calibration or operation by customer. Maintenance, adjustment, calibration or operation must be performed in accordance with instructions stated in the NO₂ Converter Quick Start Manual. Usage of maintenance materials purchased from suppliers other than 2B Technologies will void this warranty.

Limitation of Remedies and Liability

The remedies provided herein are the Customer's sole and exclusive remedies. In no event shall 2B Technologies be liable for direct, indirect, special, incidental or consequential damages (including loss of profits) whether based on contract, tort or any other legal theory. The NO₂ Converter Quick Start Manual is believed to be accurate at the time of publication and no responsibility is taken for any errors that

may be present. In no event shall 2B Technologies be liable for incidental or consequential damages in connection with or arising from the use of the NO₂ Converter Quick Start Manual and its accompanying related materials. Warranty is valid only for the country designated on the 2B Technologies quote or invoice.

ENGLISH



WARNING:

Any operation requiring access to the inside of the equipment, could result in injury. To avoid potentially dangerous shock, disconnect from power supply before opening the equipment.

WARNING:

This symbol, , on the instrument indicates that the user should refer to the manual for operating instructions.

WARNING:

If this instrument is used in a manner not specified by 2B Technologies, Inc. USA, the protection provided by the instrument may be impaired.

ESPAÑOL



ATENCIÓN:

Cualquier operación que requiera acceso al interior del equipo, puede causar una lesión. Para evitar peligros potenciales, desconectarlo de la alimentación a red antes de abrir el equipo.

ATENCIÓN:

Este símbolo, , en el instrumento indica que el usuario debería referirse al manual para instrucciones de funcionamiento.

ATENCIÓN:

Si este instrumento se usa de una forma no especificada por 2B Technologies, Inc., USA, puede desactivarse la protección suministrada por el instrumento.

FRANÇAIS



ATTENTION:

Chaque opération à l'intérieur de l'appareil, peut causer du préjudice. Afin d'éviter un shock qui pourrait être dangereux, déconnectez l'appareil du réseau avant de l'ouvrir.

ATTENTION:

Le symbol, , indique que l'utilisateur doit consulter le manuel d'instructions.

ATTENTION:

Si l'instrument n'est pas utilisé suivant les instructions de 2B Technologies, Inc., USA, les dispositions de sécurité de l'appareil ne sont plus valables.

DEUTSCH



WARNHINWEIS:

Vor dem Öffnen des Gerätes Netzstecker ziehen!

WARNHINWEIS:

Dieses, , auf dem Gerät weist darauf hin, daß der Anwender zuerst das entsprechende Kapitel in der Bedienungsanleitung lesen sollte.

WARNHINWEIS:

Wenn das Gerät nicht wie durch die Firma 2B Technologies, Inc., USA, vorgeschrieben und im Handbuch beschrieben betrieben wird, können die im Gerät eingebauten Schutzvorrichtungen beeinträchtigt werden.

ITALIANO



ATTENZIONE:

Qualsiasi intervento debba essere effettuato sullo strumento può essere potenzialmente pericoloso a causa della corrente elettrica. Il cavo di alimentazione deve essere staccato dallo strumento prima della sua apertura.

ATTENZIONE:

Il simbolo, , sullo strumento avverte l'utilizzatore di consultare il Manuale di Istruzioni alla sezione specifica.

ATTENZIONE:

Se questo strumento viene utilizzato in maniera non conforme alle specifiche di 2B Technologies, Inc. USA, le protezioni di cui esso è dotato potrebbero essere alterate.

DUTCH



OPGELET:

Iedere handeling binnenin het toestel kan beschadiging veroorzaken. Om iedere mogelijk gevaarlijke shock te vermijden moet de aansluiting met het net verbroken worden, vóór het openen van het toestel.

OPGELET:

Het symbool, , geeft aan dat de gebruiker de instructies in de handleiding moet raadplegen.

OPGELET:

Indien het toestel niet gebruikt wordt volgens de richtlijnen van 2B Technologies, Inc., USA gelden de veiligheidsvoorzieningen niet meer.

1. NO₂ CONVERTER INTRODUCTION

When used in conjunction with the Model 410 Nitric Oxide Monitor, the 2B Technologies NO₂ Converter allows measurements of NO_x (NO_x = NO + NO₂) in addition to NO. By subtraction, one can then obtain the NO₂ concentration (NO₂ = NO_x - NO). The most common application is the measurement of NO and NO₂ in urban and regional air pollution where the concentration is a few ppb or higher. NO_x measurements are achieved by passing the air stream through a molybdenum converter prior to entering the NO Monitor. In addition to providing for NO_x measurements, the NO₂ Converter has a zero air input port, which with use of a scrubber or zero air can be used to zero the Nitric Oxide Monitor. Software residing in the NO Monitor allows one to varying the cycling times between NO, NO_x and zero measurements with use of the 2 solenoid valves in the 401 converter. The 4 possible flow paths for the 401 converter are diagrammed below in fig 1.

401 NO₂ Converter Flow Path Diagram

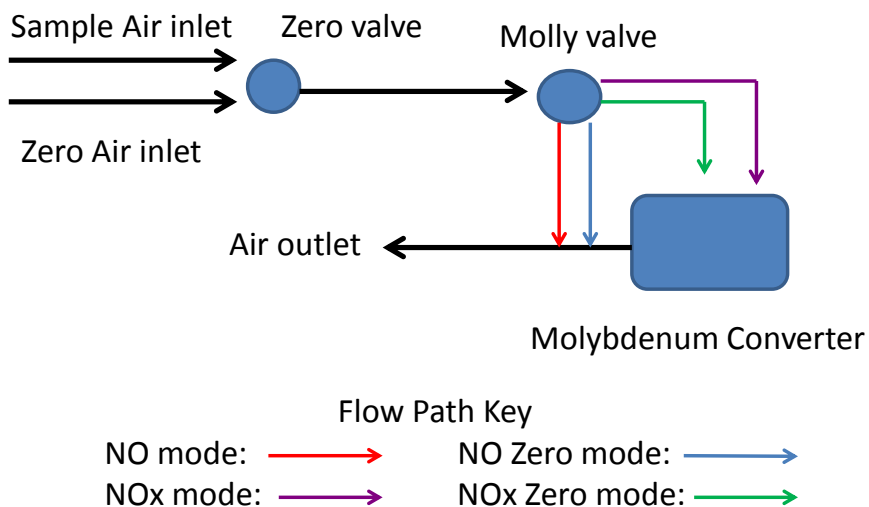

Fig. 1. NO₂ Converter flow path diagram.

NO₂ CONVERTER SPECIFICATIONS

Conversion Method Heated Molybdenum (“moly”) Oxide Surface

Converter Temperature 325 °C

Volumetric Flow Rate 1-2 L/min

Power Source Configured for either 110 VAC or 220 VAC (not both)

Power Consumption 90 Watt (max), ~45 Watt after warmup

Dimensions 3.8” x 7.5” x 9.5”

Weight..... 4.9 lb

Data Transmission 4800 baud, 8 bits, no parity, 1 stop bit

2. OPERATION

Please read all the following information before attempting to install the NO₂ Converter. For assistance, please call 2B Technologies at (303)273-0559 or email techsupport@twobtech.com.

NOTE:

Save the shipping carton and packing materials that came with the Nitric Oxide Monitor. If the Nitric Oxide Monitor must be returned to the factory, pack it in the original carton. Any repairs as a result of damage incurred during shipping will be charged.

Shipping Box Contents

Open the shipping box and verify that it contains all of the items on the shipping list. If anything is missing or obviously damaged, contact 2B Technologies immediately.

Operation of the NO₂ Converter

To operate the NO₂ Converter, use the power cord to connect it to AC power and turn the instrument on by flipping the front panel power switch. The instrument requires either 110 V or 220 V AC.

The target temperature should be set to 325 °C on the temperature controller on the front of the instrument. This target temperature will have been preset at the factory and there should be no reason to change it. However, if for some reason it is necessary to reset the target temperature, please see the instructions for the temperature controller included with the instrument.

Air is sampled into the inlet of the NO₂ Converter. You may connect an inlet tube at the connector marked "Inlet." Connect the provided tubing between the Model 401 Converter Outlet and 410 NO monitor Inlet as shown in Fig. 2 below. All inlet and connecting tubing must be an inert material such as PTFE or PTFE-lined Tygon that does not adsorb or react with NO or NO₂. Flow is drawn into and through the NO₂ Converter by the NO Monitor and should be at a volumetric flow rate in the range 1-2 L/min. The sample flow rate into the NO

Monitor must be in excess of 800 cc/min in order to assure an overflow within the internal overflow sampling tee.

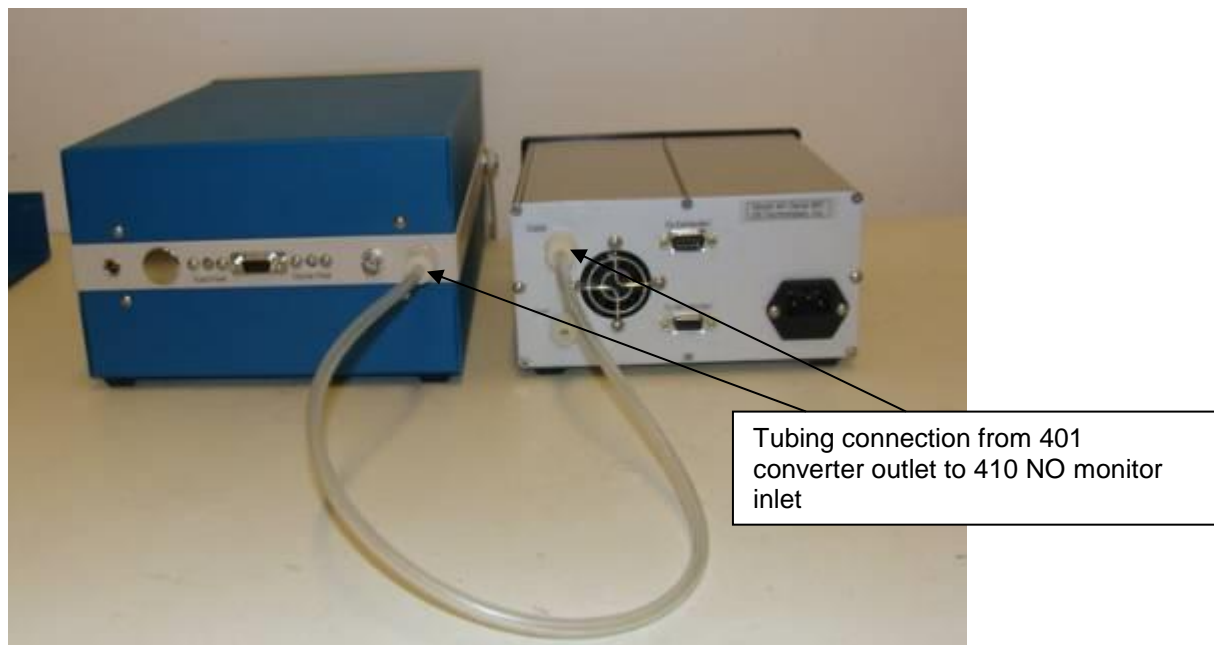

Fig. 2

Use the 9 pin male-male RS232 accessory cable to connect the serial port connector of the Model 401 NO₂ Converter labeled "To NO Monitor" to the serial port connector of the Model 410 NO Monitor, as shown in Fig. 3 below.

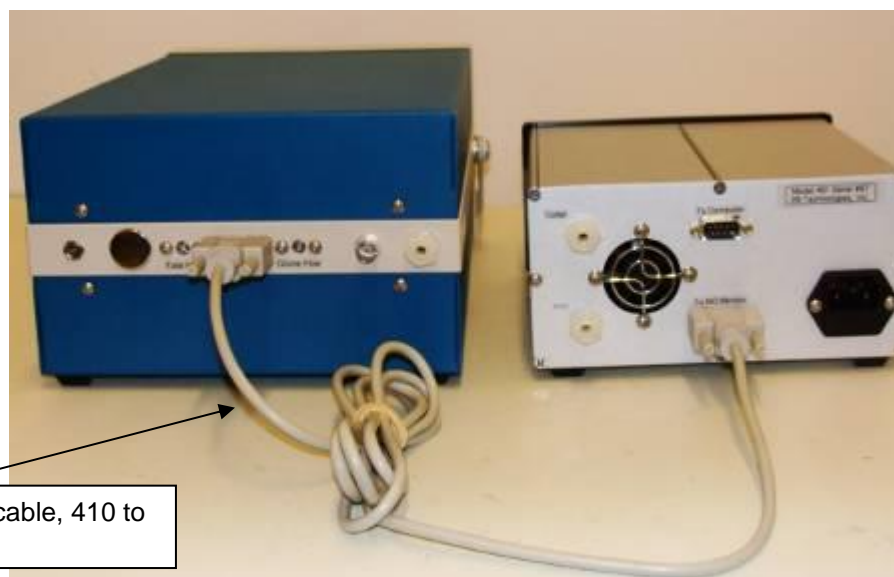

Fig. 3

This cable allows the NO Monitor to control the solenoid valves inside the NO₂ Converter so as to measure either NO, NO_x or NO_x-scrubbed air (instrument zero). This male-male RS232 accessory cable also passes serial data from the NO Monitor through the NO₂ Converter, and then outputs to the serial data port on the back side of the NO₂ Converter labeled “To Computer”.

If you wish to collect data with your computer, connect the female-female RS232 serial cable between the back of the NO₂ Converter serial port labeled “To Computer” and the computer to be used to collect the data as shown in Fig. 4 below.

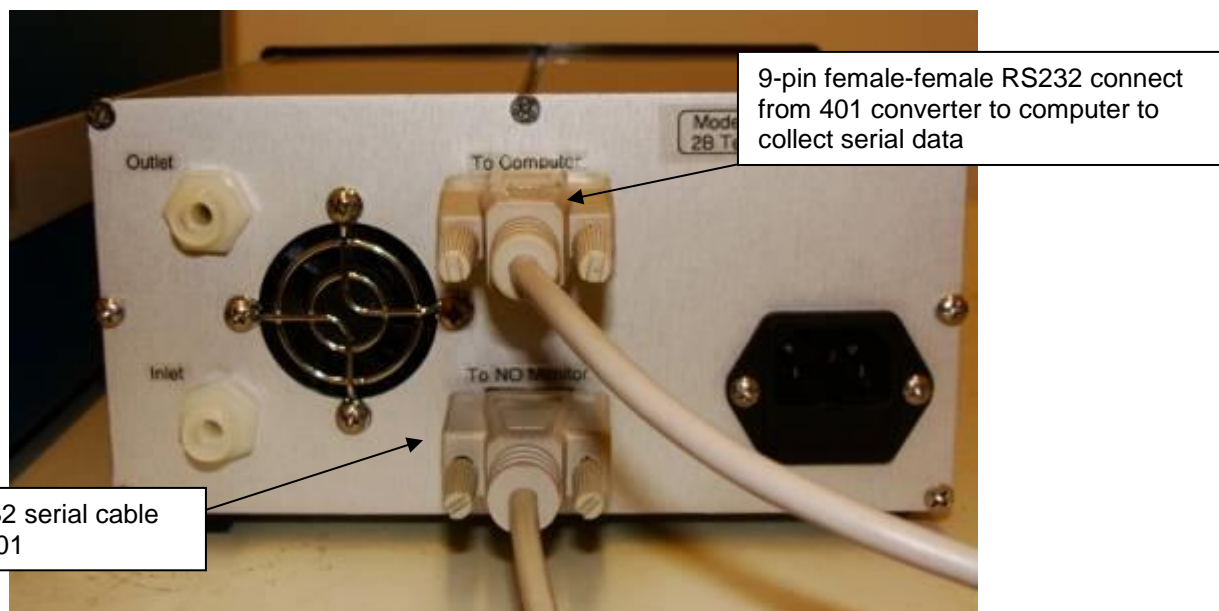

Fig. 4

If your computer does not have a serial port, you can use a serial-to-USB adapter and collect the data over your computer’s USB port. Please see the NO Monitor Manual or the 2B Technologies software downloads page for details on collection of data from your serial port using the 2B Tech Display and Download Software here:

http://twobtech.com/downloads_software.htm

Alternatively, instructions for the use of Tera Term Pro and Hyperterminal for collection of serial port data are given in Tech Note No. 007:

http://www.twobtech.com/tech_notes/TN007.pdf

Setting the Frequencies of NO, NO_x and Zero Measurements

If you purchased the NO₂ Converter along with a 2B NO Monitor, software on the NO Monitor will operate the functions of the NO₂ Converter. This software will allow you to choose the frequencies of NO, NO_x and Zero measurements. The main menu of the NO monitor, which is accessed by holding the Select Button, will appear as:

Dat Avg Cfg Mol

Selecting the **Mol** (for “molybdenum” or “moly” converter) submenu gives:

NOx Zer Dur

The **NOx** submenu allows you to set the NO_x measurement function to be always off (i.e., only measure NO), always on (only measure NO_x) or to cycle between NO and NO_x measurements at frequencies of 5 min, 15 min or 1 hr.

The **Zer** submenu allows you to turn the zeroing function to always off, always on or to scheduled zero measurement at frequencies of 30 min, 1 hr or 4 hr.

Note:

The user must attach zero air or a zeroing scrubber to the 401 zero air inlet port for the zeroing functionality to work properly

The **Dur** submenu allows you select the duration of time to run the scheduled zero mode. The user can select to run the zero for 5 min, 15 min, or 1 hr.

Status Bytes

When using the NO₂ Converter with the Model 410 NO monitor, data is output over the serial port and logged to internal memory in the same way as described in the NO Monitor Manual. The status byte 2nd to last on the 410 data stream indicates what mode the 410 NO₂ Converter is in. The meaning of each Status Byte follows:

Status Byte	Meaning
0	NO being measured, NO _x not scheduled, Zero not scheduled
1	NO _x being measured, NO scheduled, Zero not scheduled
2	Zero being measured, NO scheduled, NO _x not scheduled
3	Zero (through Moly), NO scheduled, NO _x not scheduled

- 4 NO being measured, NOx scheduled, Zero not scheduled
- 6 Zero being measured, NO and NOx scheduled
- 8 NO being measured, NOx not scheduled, Zero scheduled
- 9 NOx being measured, NO scheduled, Zero scheduled
- 12 NO being measured, NOx scheduled, Zero scheduled
- 16 NOx measured all the time
- 32 Zero measured all the time (through NO)
- 48 Zero measured all the time (through Molly)

3. ELECTRIC WIRING DIAGRAM

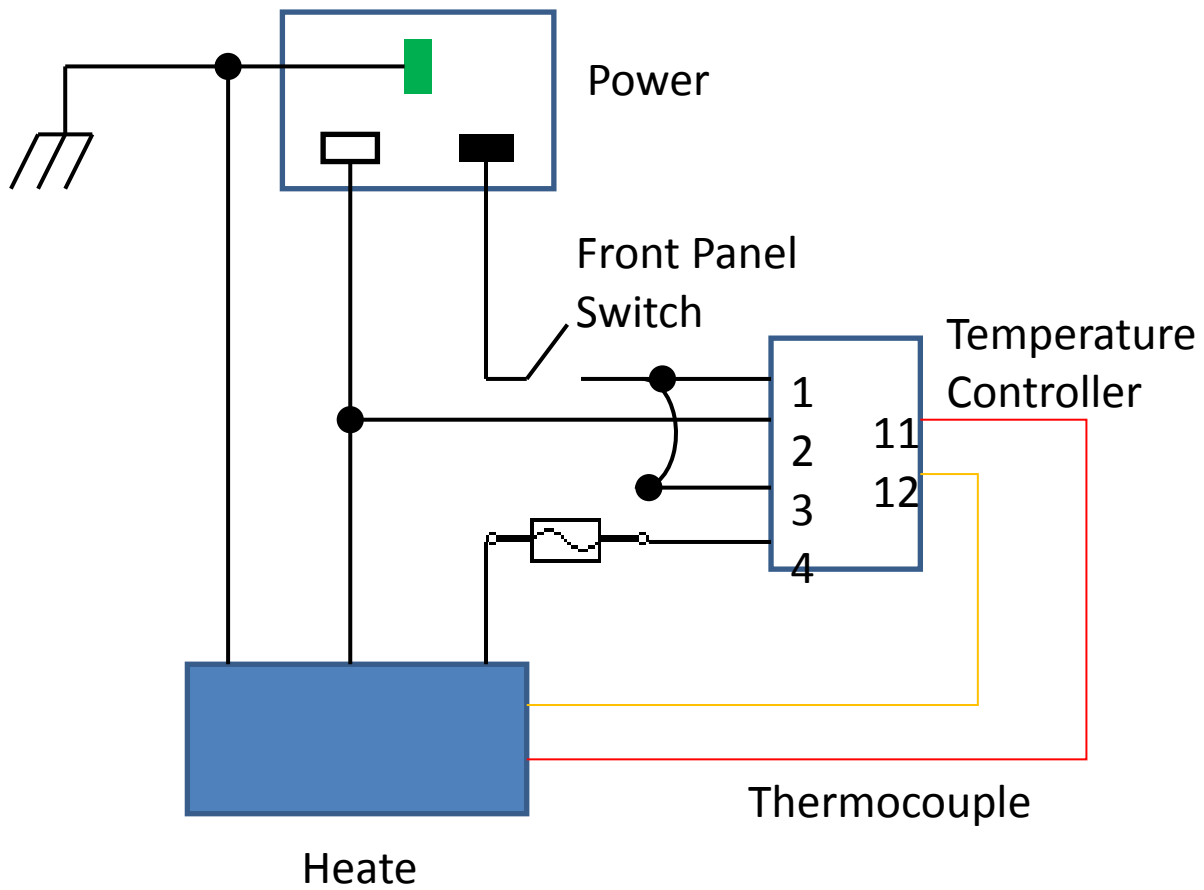

Fig. 2. Electrical Wiring Diagram for Model 401 NO₂ Converter.

4. TROUBLE SHOOTING

Most issues with the Model 401 Converter are related to the temperature controller, heater, or heater fuse. Below is a table with common issues and troubleshooting tips. While it is recommended to send back the 401 converter to 2B Tech for repairs, customer comfortable with trouble shooting and basic electronics can take on some repairs on their own.

WARNING: The Model 401 NO₂ Converter uses AC power and draws large amounts of current. BE SURE THE CONVERTER IS POWERED OFF AND UNPLUGGED BEFORE BEGINNING TROUBLE SHOOTING STEPS

Problem/Symptom	Likely Cause	Corrective Action
Unit does not power on	Power not supplied to 401	Make sure power cord supplied by 2B tech is connected to a 120 V or 220 V AC power source.
	Blown power jack fuse	Pull out fuse inside power jack on back panel of Model 401 and verify continuity of fuse. If not continuous, replace fuse.
Unit heats up but NOT all the way up to 325 °C or does not hold temperature at 325 °C	Heater failure	Contact 2B tech for 401 heater replacement.
Temperature Controller displays blinking "S.Err"	Issue with heater thermocouple (temperature sensor)	Verify yellow and red wires are tightly connected to pin 11 (red) and pin 12 (yellow). If so and error still occurs, thermocouple needs replacement

Data does not transmit from Model 410 to Model 401 to PC	Issue with serial cable set up	Verify proper cable set up with use of RS232 cables sent from 2B Tech (or using 9-pin straight through RS232 cables). See pic(s) in Operation of NO ₂ converter above for verification of set up.
Zero mode causes Model 410 to display large zero offset that is NOT present when the Model 410 is in use without the Model 401 converter.	zeroing air/scrubber contamination	Replace zeroing scrubber.
NO Monitor always measures near zero when connected to the Model 401	Zero valve not functioning properly so that 410 is pulling from zero air port	Verify that the zero valve is functioning properly. In NO or NO _x mode voltage between pins 8 & 9 of breakout box inside back panel of 401 converter with zero function OFF should be 0V.
NO Monitor does not zero when in zero mode	RS232 cables not connected properly Zero function not selected in menu	Verify that RS232 cables are connected to Models 401 and 410 properly (see NO ₂ Converter operation section above). Verify that the zero function in Model 410 menu is selected via status byte on serial readout.

	Zero valve powered	Verify power to zero valve. Voltage between pins 8 & 9 of breakout box inside back panel of 401 converter with zero function ON should be 12 V.
Values of NO _x and NO are the same when known concentration of NO ₂ is added to system	RS232 cables not connected properly	Verify that RS232 cables are connected to Models 401 and 410 properly (see NO ₂ Converter operation section above). Verify NO _x function in 410 menu is selected via status byte on serial readout. Verify power to NO _x valve. Voltage between pins 6 & 7 of breakout box inside back panel of 401 converter with NO _x function ON should be 0 V. With NO _x and zero function OFF the voltage should be 12 V.
Obnoxious odor coming from NEW Model 401 Converter when warming up	Insulation around molybdenum converter is outgassing	While the converter has been through a burn in process at 2B, it is common for them to outgas this smell for a short period of time when new.
Conversion efficiency drops below 90% when given a “known” concentration of NO _x	Model 410 calibration for NO changed Loss of conversion efficiency	Check calibration of Model 410 for NO. The molybdenum converter will lose

		efficiency over time due to changes in the oxidation states of surface site. The converter will require regeneration or which can be done by 2B Tech or by the customer. Please contact us.
--	--	---

Fig. 5