

Black Carbon Photometer™

Direct Measurement of Black Carbon without Filter Preconcentration



The Black Carbon Photometer™ (BCP™) is a rugged, portable, highly accurate and economical instrument for measuring atmospheric black carbon particulates in polluted urban environments. The BCP uses the simple and direct technique of long-path photometry to quantify—in real time—the total extinction and mass concentrations of particulates in the aerosol (gas + particle) phase. This direct approach avoids the artifacts and other issues associated with current commercially available instruments, such as the most common current technique of aethalometry that uses filters to preconcentrate samples for analysis.

The detection cell of the Black Carbon Photometer has a [patented](#) folded tubular design, an innovation that enables it to be rapidly flushed (necessary for fast switching between sample and reference measurements). Consequently, the BCP has high sensitivity, needs no preconcentration on a filter, and gives fast measurements of black carbon. The absorption cell is folded to give a long (2.1-meter) path length in a compact space, resulting in an instrument that is light weight (~19.2 lb/8.7 kg) and sized for use in a standard rack mounting system (see our paper on the folded tubular photometer: [Birks et al., *Atmospheric Measurement Techniques*, 11, 2821-2835, 2018](#)).

The Black Carbon Photometer is designed for the direct measurement of total extinction (absorbance + scattering) due to particulate matter at two wavelengths, 405 nm and 880 nm, in units of Mm^{-1} . The 880-nm channel can be used to compute black carbon mass concentration in the range 0.1 – 1,300 $\mu g m^{-3}$. Extinction at the shorter 405 nm wavelength can be related empirically to PM_{2.5} in a given location.

The Black Carbon Photometer is useful for researchers studying the role of black carbon in air quality and climate, and for air quality managers interested in estimating community exposure risks.

Theory of Operation

The figure below is a simplified schematic diagram of the Black Carbon Photometer. Sample air is continuously drawn through the instrument and its optical detection cell by an air pump at a flow rate of ~1.0-1.6 L/min. The reference valve alternately bypasses or sends the sample air through a PTFE particulate filter (labeled Particulate Filter #1 below) that removes all particulates in the sample, thus allowing the alternating measurement of a light intensity in the absence of particulates (I_o) and presence of particulates (I). The Beer-Lambert Law is then used to calculate the particulate extinction (B_{ext}) from I and I_o :

$$B_{ext} = \frac{1}{L} \ln\left(\frac{I_o}{I}\right) \quad (1)$$

Here, L is the path length (2.1 m).

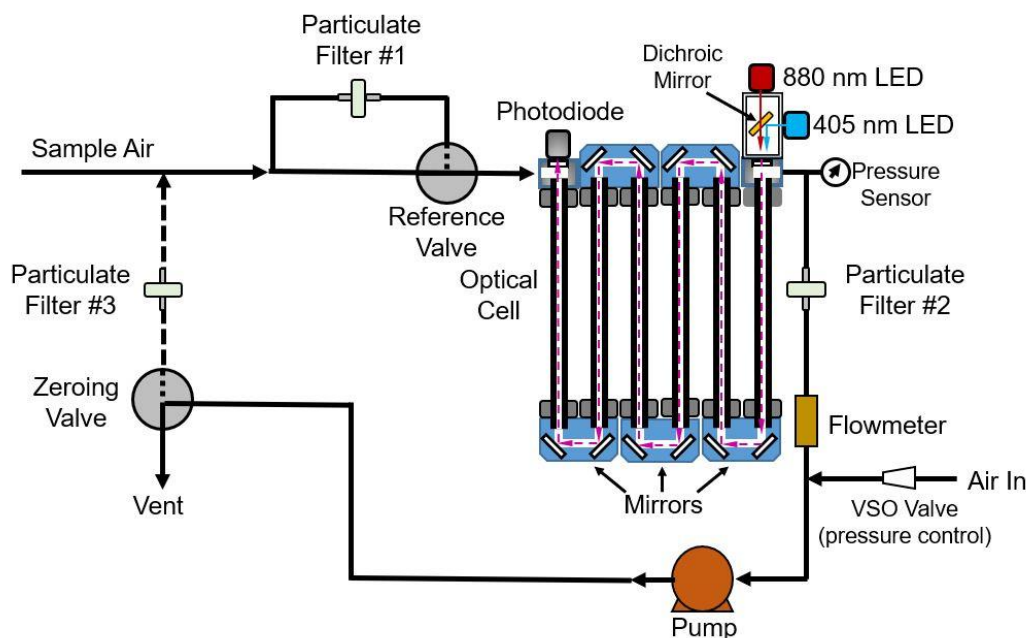

Simplified schematic diagram of the Black Carbon Photometer (BCP)

Particulate extinction is the sum of two factors: aerosol absorption (B_{abs}) and scattering (B_{sct}):

$$B_{ext} = B_{abs} + B_{sct} \quad (2)$$

At the longer wavelength of the Black Carbon Photometer (880 nm), absorption is a much larger contributor to extinction. In polluted urban air, the response of the instrument at 880 nm is primarily due to black carbon absorption. The measured extinctions are converted to black carbon concentrations (C_a , $\mu\text{g m}^{-3}$) by using an appropriate black carbon absorption coefficient (σ_{abs} , $\text{m}^2 \text{g}^{-1}$) at 880 nm: $C_a = B_{ext}/\sigma_{MEC} \cong B_{ext}/\sigma_{abs}$. At the shorter wavelength of the instrument (405 nm), scattering dominates and the instrument response is more indicative of total aerosol concentration. A default value of the mass extinction coefficient (σ_{MEC}) for black carbon at 880 nm is used in the instrument, but σ_{MEC} at both wavelengths can be easily modified by the user depending upon the sampling environment.

Features

- Direct measurement of extinction by particulates at two wavelengths (880 nm and 405 nm) enables real-time measurements of particulate matter, including black carbon, and PM2.5.
- Direct approach eliminates the need to preconcentrate samples on filters, thereby avoiding associated artifacts
- Power consumption: ~16 watts after warmup
- Lightweight (~19.2 lb, 8.7 kg), standard rack-mount size
- Long-life pump (~15,000 hours)
- Touchscreen
- USB port for portable data logging
- Internal data logger capacity: 10 Gbytes
- Both serial and user-scalable analog voltage outputs
- Convenient user interface to microprocessor, via either touchscreen or serial, including calibration parameters (gain and zero) and mass conversion coefficients
- Selectable measurement time of 10 s or data averaging times of 1 min, 5 min and 1 hr
- Built-in zeroing capability
- Requires little technical maintenance and is suitable for continuous operation under field conditions (capable of battery-powered operation)
- Economical when compared with other commercially available instruments

Specifications

Principle of Measurement	Direct extinction at 405 and 880 nm
Measurement Outputs	Extinction (Mm^{-1}) at 405 and 880 nm Mass concentration ($\mu g m^{-3}$) at 880 nm
Linear Dynamic Range	0-10,000 Mm^{-1} (~0-1300 $\mu g m^{-3}$ at 880 nm)
Resolution	0.1 Mm^{-1} (0.1 $\mu g m^{-3}$)
Precision (10-s measurement, 1σ rms noise)	405 nm: 4.1 Mm^{-1} ; 0.7 Mm^{-1} with adaptive filter ¹ 880 nm: 2.8 Mm^{-1} ; 0.5 Mm^{-1} with adaptive filter ¹ (0.35 $\mu g m^{-3}$; 0.07 $\mu g m^{-3}$ with adaptive filter ^{1,2}) 880 nm, 1-hr avg: 0.018 $\mu g m^{-3}$
Accuracy	Greater of 2 Mm^{-1} or 2% of reading
Limit of Detection (2σ)	405 nm: < 1.6 Mm^{-1} (with adaptive filter ¹) 880 nm: < 1.1 Mm^{-1} (with adaptive filter ¹) 880 nm, 1-hr avg: 0.036 $\mu g m^{-3}$
Flow Rate (nominal)	1.3 Liter/min
Flow Rate Requirement	Minimum: 1.0 Liter/min; Maximum: 1.6 Liter/min
Response Time, 100% of Step Change	20 s for 10-s averaging 30 s with adaptive filter ¹

Measurement Frequency	0.1 Hz (once every 10 s)
Averaging Times	10 s, 1 min, 5 min, 1 hr
Internal Data Logger Capacity	10 Gbytes, > 3.2 years of 10-s data
USB for Portable Data Logging	Yes
Pressure Units	mbar
Temperature Units	°C
T and P Corrected	User-Selected
Operating Temperature Range	5 to 45°C
Operating Pressure	600 - 1000 mbar
Power Requirement; 2.5-amp 110/220 VAC Power Pack (provided) or Battery	11-14 V dc or 120/240 V ac, 1.3 A at 12 V, 16 watt average
Size	Rackmount: 17" w × 14.5" d × 5.5" h (43 × 37 × 14 cm)
Weight	19.2 lb (8.7 kg)
User Interface	Touchscreen or Serial
Data Outputs	RS232; 0-2.5 V Analog Outputs for 405 and 880 nm extinctions; USB drive
Data Transfer Baud Rate	2400
Output Ranges	User-defined scaling factor in menu
Long Life Pump	Yes: 15,000 hr
Flow Meter	Yes
Built-In Auto-Zeroing Capability	Yes

¹ An adaptive filter may be selected from the serial menu for signal averaging. Specifications above are for default parameters: Minimum Absolute Difference = 15 Mm⁻¹, Percent Difference = 5%, Short Filter = 4 pts (40 s), Long Filter = 18 pts (3 min). Adaptive filter parameters may be adjusted by the user.

² Using a default mass extinction coefficient of 7.77 m² g⁻¹. This value can be adjusted by the user.

System Includes

- Black Carbon Photometer
- 2.5A Power Adapter (2.5 amp, 100-240 VAC to 12 VDC) with select power cord
- Serial Port Cable (9PinF-9PinF)
- Operation Manual on USB Stick
- Calibration Data and NIST-Traceable Calibration Certificate
- Instrument Birth Certificate
- One-Year Warranty